



AD-C820/C821

AcousticDesign™ High-output Ceiling Mount Loudspeakers

Features

- 8" low-frequency woofer
- 1.4" diaphragm compression driver
- 200 watt continuous power rating
- 70V/100V multi-tap transformer included (system can operate in distributed or low-impedance mode)
- AD-C820 transducer/baffle assembly for separated backcan installation
- AD-C821 designed as a fully integrated blind-mount system



The AD-C820 and AD-C821 are acoustically identical and designed for music playback, public address and distributed audio in applications that require high output from a ceiling mounted loudspeaker. The AcousticDesign™ Series of installation loudspeakers has been designed for trouble free operation and versatility. Both models use custom designed transducers and crossover networks, in combination with an acoustically optimized enclosure (AD-C800BB), or as a fully integrated, sealed system (AD-C821). These loudspeakers continue the AD Series philosophy of bringing natural and accurate sound quality combined with versatility and reliability to high-ceiling applications.

The AD-C820 assembly includes the coenrant transducers, a 70V/100V transformer and a crossover mounted on an ABS baffle. When ordered as a system (AD-C820R SYSTEM; AD-C820S SYSTEM) the backbox (AD-C800BB) and a round or square grille are included.

The AD-821 is a fully integrated, factory sealed system using a "dog-ear" style mounting scheme. When ordered as a system (AD-C821R SYSTEM; AD-C821S SYSTEM) a set of tile rails and a c-ring are included as is a round or square grille.

The 8" woofer is equipped with a treated paper cone on a steel frame. In the optimized enclosure the usable low frequency of the system extends to 52 Hz. The 1.4" compression driver fires through the center of the woofer and is acoustically mated to the woofer for a smooth transition at crossover. The system achieves 90 degree axisymmetric coverage.

High-current, low tolerance network components provide smooth full-range, passive performance. The included 70V/100V, custom designed transformer is optimized for low line loss as well as accurate and transparent acoustic performance.

The AD-C820/C821 loudspeakers measure 91dB sensitivity (1W/1m) and at full continuous power are capable of producing 114 dB SPL (1W/1m) output.

Specifications	AD-C820	AD-C821
Configuration	Passive	
Transducers		
Low-frequency	8" (203 mm) ferrite woofer	
High-frequency	1.4" (36 mm) neodymium compression driver	
Frequency Range ¹		
Frequency Response (-6 dB)	61 Hz – 18 kHz	
Useable Frequency Range (-10 dB)	52 Hz – 18 kHz	
Maximum Output ²		
Calculated Peak Output	120 dB SPL	
Calculated Continuous Output	114 dB SPL	
Nominal Coverage	90° horizontal and vertical	
Nominal Impedance	16Ω	
Power Rating		
RMS Power Handling ³	200 W	
Recommended Max Amp Power	400 W	
Sensitivity	91 dB SPL, 1W/1m	
Bass Loading	Ported	
Transformers		
Type	Custom low distortion laminated core, wide bandwidth design	
Taps	100 V: 16Ω bypass, 100 W, 50 W, 25 W 70 V: 16Ω bypass, 100 W, 50 W, 25 W, 12.5 W	
Agency Rating	CE, UL 1480 (commercial/professional use) UL 2043 (air handling spaces)	
Enclosure Volume	AD-C800BB: 18 L (0.64 ft ³) 18 L (0.64 ft ³)	
Enclosure		
Connectors	Back box (AD-C800BB): ceramic block connector inputs and "through" connectors (rated for 400 W max). Loudspeaker Baffle (AD-C820): 10-pin MATE-N-LOK™ connector and faston connectors.	Two 2-pin Euro-style connectors
Mounting Hardware	Pre-installed, suspended, back box, four vertical mounting straps. Loudspeaker Baffle: captive, integral Mounting Clamps.	Captive, integral Mounting Clamps. Insert enclosure into mounting hole, and tighten. Suspended ceiling Split-ring and Suspended Ceiling Tile Rails - sold separately.
Weight - Net	AD-C820: 8 lb (3.6 kg) AD-C800BB: 9.5 lb (4.3 kg) System Weight: 17.5 lb (7.9 kg)	16 lb (7.3 kg)
Dimensions	Diameter: 14.9" (379 mm) Enclosure only Depth: 8.3" (211 mm) Enclosure with mounting straps Depth: 11.2" (284 mm)	Diameter: 13.4" (340 mm) Depth: 11.9" (302 mm)
System Packages	AD-C820R SYSTEM: includes AD-C820 speaker baffle, AD-C800BB back-box, AD-C800RG round grille AD-C820S SYSTEM: includes AD-C820 speaker baffle, AD-C800BB back-box, AD-C800SG square grille	AD-C821R SYSTEM: includes AD-C821 loudspeaker system, AD-C800RG round grille, and set of tile rails and c-ring AD-C821S SYSTEM: includes AD-C821 loudspeaker system, AD-C800SG square grille, and set of tile rails and c-ring

1) All frequency ranges specified refer to measured half-space response (2 pi).

2) Calculated maximum peak SPL at 1 m, half-space, speaker operating at rated rms power pink noise input, 50 Hz – 20 kHz.

3) Maximum input power tested in accordance with IEC recommendations; 50 Hz – 20 kHz band limiting, 6 dB signal crest factor.

AD-C820/C821

Dimensions

AD-C820/AD-C821

Front

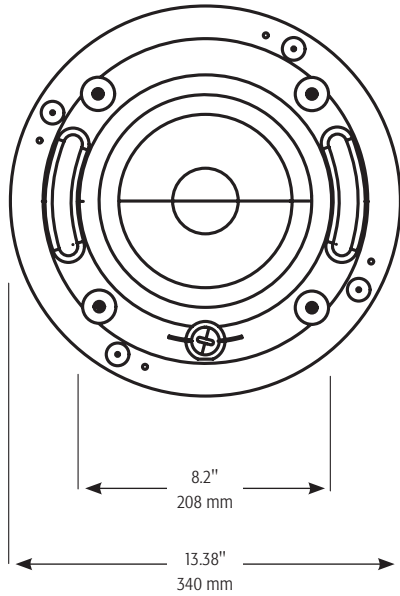

AD-C821

Side

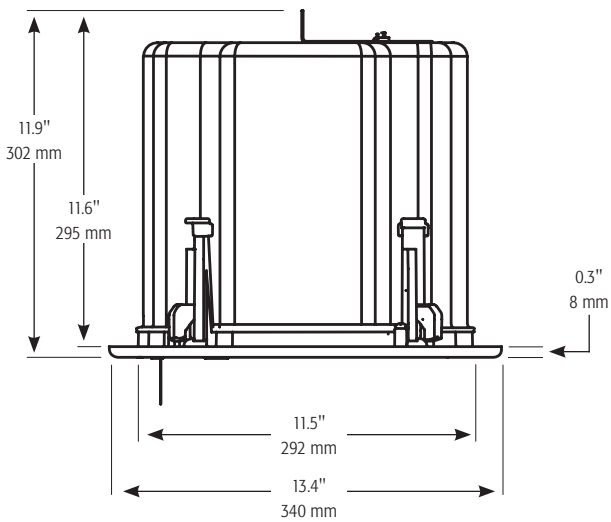

AD-C820

Side

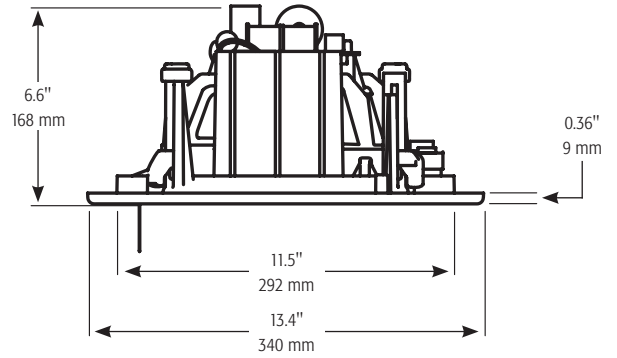

AD-C800BB

Side

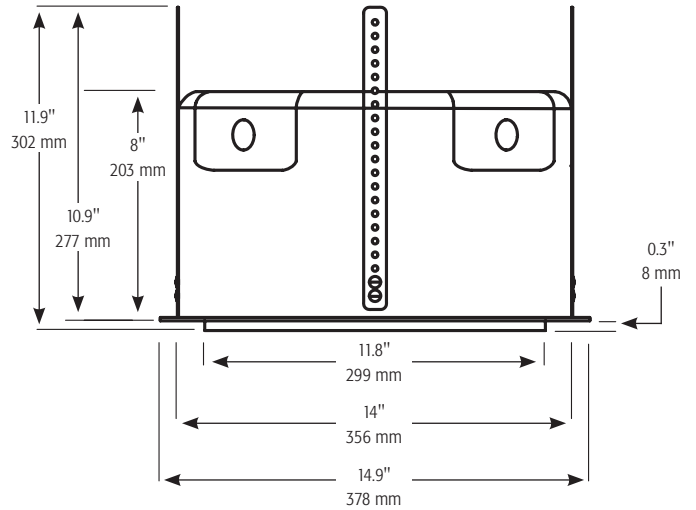

AD-C800RG

Side

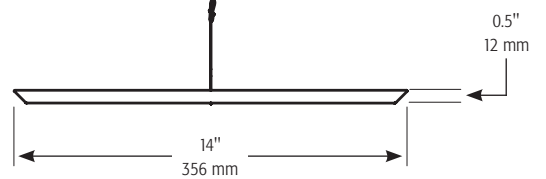

AD-C800SG

Side

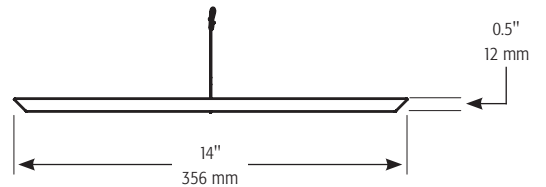

Specifications subject to change without notice.

please recycle 

©2010 QSC Audio Products, LLC. All rights reserved. QSC and the QSC logo are registered trademarks of QSC Audio Products, LLC in the U.S. Patent and Trademark office and other countries. AcousticDesign is a trademark of QSC Audio Products, LLC. MATE-N-LOK is a trademark of Tyco. All other trademarks are the property of their respective owners. Patents may apply or be pending.

1675 MacArthur Boulevard • Costa Mesa, CA 92626 • Ph: 800/854-4079 or 714/957-7100 • Fax: 714/754-6174

AD-C820/C821 Spec Sheet - 09/01/10

QSC
qscaudio.com